

## ALTIVAR® 71 GRAPHIC DISPLAY TERMINAL

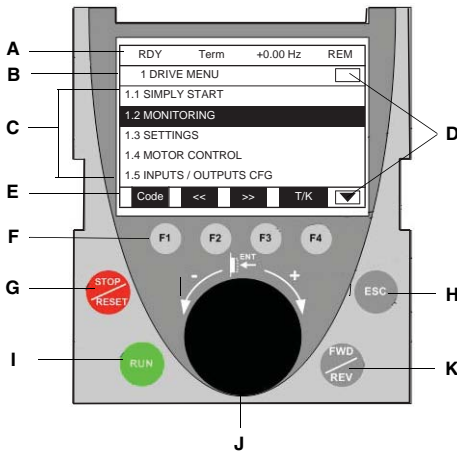

### Description and Operation

- A** Display Status: Displays default settings—the drive's state, active control channels, frequency reference, and LOC/REM (T/K key status). The Display Status content can be configured.
- B** Menu line: Displays the name of the current menu or submenu.
- C** Submenus: Lists the submenus of the current menu.
- D** Scroll boxes: Indicates (by arrow direction) whether there are additional submenus or levels to access. A blank box indicates that there are no additional submenus or levels to access.
- E** Status line displays the functions assigned to function buttons F1–F4. Code = F1, << = F2, >> = F3, and T/K = F4. See the descriptions below.
- F** Function buttons—  
**F1** displays the code of the selected parameter or contextual Help.  
**F2** provides navigation to the left / returns to the previous menu or submenu  
**F3** provides navigation to the right / advances to the next menu or submenu  
**F4** command and reference via the terminal
- G** Stop/Reset button—stops the drive controller and resets the faults
- H** ESC button—exits a menu or parameter, or cancels a value to return to the previous value in the memory
- I** Run button—runs the motor with the current setting. Starts the drive controller if in HMI command mode.
- J** Navigation button/dial—pressing the button saves a value or enters a menu or parameter. Turning the dial clockwise increases a value. Turning the dial counter-clockwise advances to the next menu item or line, or decreases the reference (if terminal control is active).
- K** FWD/REV button—reverses the rotation direction of the motor (if configured to allow reverse for HMI command mode).

NOTE: Refer to the Altivar 71 programming manual for detailed information about the display terminal operations.

## PROGRAMMING PARAMETERS

Example of accessing the acceleration ramp setting

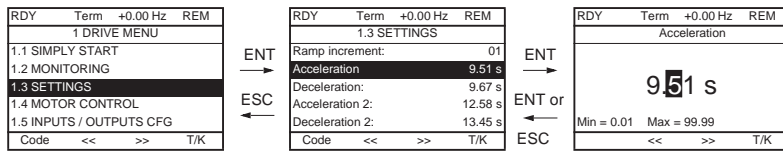

### Changing a parameter

1. Use the navigation dial to vertically scroll the DRIVE MENU list, press ENT (navigation button) to select the submenu.
2. Select the parameter to change and press ENT.
3. Use F1 and F2 to scroll horizontally, then select the digit to change (the digit is highlighted).
4. Turn the navigation dial clockwise to increase the digit or counter-clockwise to decrease the digit.
5. Press ENT to save the change or press the ESC button to cancel the change.

## MACRO CONFIGURATION PARAMETERS

Input/output	[Start/Stop]	[M. handling]	[Gen. Use]	[Hoisting]	[PID regul.]	[Network C.]	[Mast./ slave]
A11	[Ref.1 channel]	[Ref.1 channel]	[Ref.1 channel]	[Ref.1 channel]	[Ref.1 channel] (PID reference)	[Ref.2 channel] ([Ref.1 channel] = integrated Modbus (1))	[Ref.1 channel]
A12	[No]	[Summing ref. 2]	[Summing ref. 2]	[No]	[PID feedback]	[No]	[Torque ref. 1]
AO1	[Motor freq.]	[Motor freq.]	[Motor freq.]	[Motor freq.]	[Motor freq.]	[Motor freq.]	[Sign torque]
R1	[No drive fit]	[No drive fit]	[No drive fit]	[No drive fit]	[No drive fit]	[No drive fit]	[No drive fit]
R2	[No]	[No]	[No]	[Brk control]	[No]	[No]	[No]
L11 (2-wire)	[Forward]	[Forward]	[Forward]	[Forward]	[Forward]	[Forward]	[Forward]
L12 (2-wire)	[Reverse]	[Reverse]	[Reverse]	[Reverse]	[Reverse]	[Reverse]	[Reverse]
L13 (2-wire)	[No]	[2 preset speeds]	[Jog]	[Fault reset]	[PID integral reset]	[Ref.2 switching]	[Trq/spd switching]
L14 (2-wire)	[No]	[4 preset speeds]	[Fault reset]	[External fault]	[2 preset PID ref.]	[Fault reset]	[Fault reset]
L15 (2-wire)	[No]	[8 preset speeds]	[Torque limit]	[No]	[4 preset PID ref.]	[No]	[No]
L16 (2-wire)	[No]	[Fault reset]	[No]	[No]	[No]	[No]	[No]
L11 (3-wire)	Stop	Stop	Stop	Stop	Stop	Stop	Stop
L12 (3-wire)	[Forward]	[Forward]	[Forward]	[Forward]	[Forward]	[Forward]	[Forward]
L13 (3-wire)	[Reverse]	[Reverse]	[Reverse]	[Reverse]	[Reverse]	[Reverse]	[Reverse]
L14 (3-wire)	[No]	[2 preset speeds]	[Jog]	[Fault reset]	[PID integral reset]	[Ref.2 switching]	[Trq/spd switching]
L15 (3-wire)	[No]	[4 preset speeds]	[Fault reset]	[External fault]	[2 preset PID ref.]	[Fault reset]	[Fault reset]
L16 (3-wire)	[No]	[8 preset speeds]	[Torque limitation]	[No]	[4 preset PID ref.]	[No]	[No]
Option cards							
L17 to L114	[No]	[No]	[No]	[No]	[No]	[No]	[No]
LO1 to LO4	[No]	[No]	[No]	[No]	[No]	[No]	[No]
R3/R4	[No]	[No]	[No]	[No]	[No]	[No]	[No]
A13, A14	[No]	[No]	[No]	[No]	[No]	[No]	[No]
RP	[No]	[No]	[No]	[No]	[No]	[No]	[No]
AO2	[I motor]	[I motor]	[I motor]	[I motor]	[I motor]	[I motor]	[I motor]
AO3	[No]	[Sign. torque]	[No]	[Sign. torque]	[PID Output]	[No]	[Motor freq.]
Graphic display terminal keys							
F1 key	[No]	[No]	[No]	[No]	[No]	Control via graphic display terminal	[No]
Keys F2, F3, F4	[No]	[No]	[No]	[No]	[No]	[No]	[No]

In 3-wire control, the assignment of inputs L11 to L17 shifts.

## TYPICAL CONNECTIONS

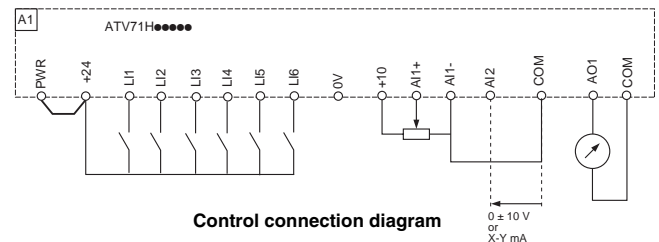
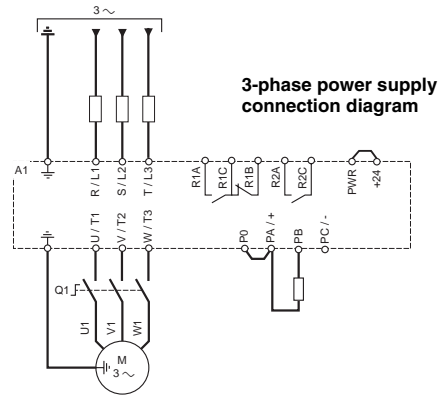

NOTE: The graphic display terminal is standard on all ATV71 variable speed drives. ATV71 low hp drive controllers can also be ordered without the terminal and equipped instead with a 7-segment, 4-digit integrated display terminal.

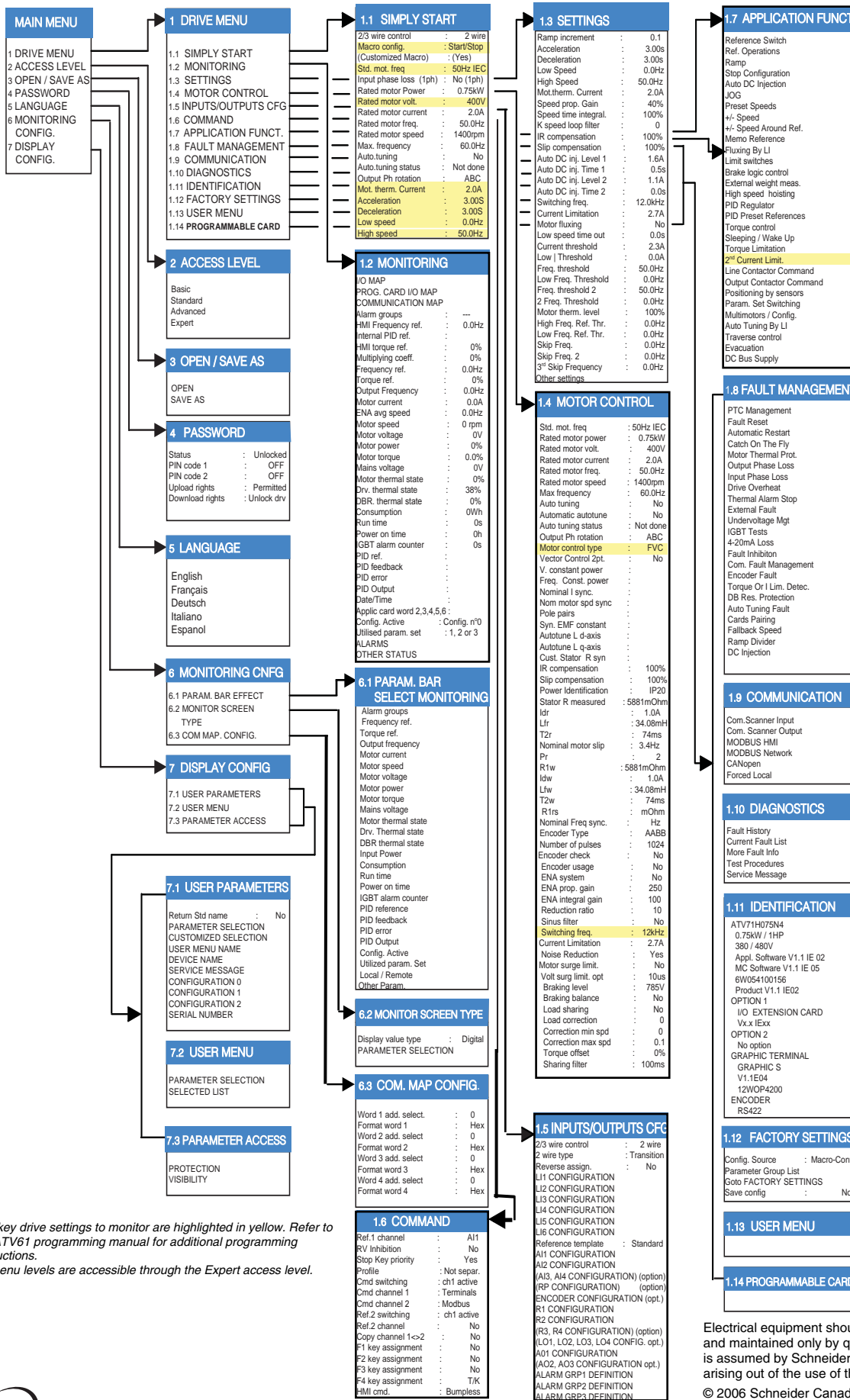

**NOTE:**

- The key drive settings to monitor are highlighted in yellow. Refer to the ATV61 programming manual for additional programming instructions.
- All menu levels are accessible through the Expert access level.

Electrical equipment should be installed, operated, serviced, and maintained only by qualified personnel. No responsibility is assumed by Schneider Electric for any consequences arising out of the use of this material.

© 2006 Schneider Canada All Rights Reserved